

TRANSPORTATION INSIGHTS

Nine Ways Leasing Can Reduce Risk

Utilizing a full-service lease can minimize the unknowns private fleets face. Penske Truck Leasing talked with chief financial officers and key leaders to uncover nine ways they use leases to reduce risk.

Control Costs

Leasing provides peace of mind related to a private fleet's finances. A full-service lease can give companies a better handle on the actual month-to-month costs associated with a vehicle and minimize the volatile costs that come with ownership. Without a lease, maintenance costs can create a large unknown for private fleets, but leasing eliminates the question marks since the lease and maintenance payment is flat.



Plus, Penske's MyFleet application provides detailed insight into each leased unit's running costs. The app breaks out costs for each unit, which gives users a general overview of the vehicles, as well as specific costs by unit number and location. This allows a fleet manager to focus on units that have a higher operating cost to determine the root cause, such as driver behavior.

Decrease Operational Risks

The primary goal of operations is to fulfill the obligations to the customer, which means equipment uptime is crucial. Missing a pickup or delivery due to a breakdown or lack of equipment is not an option. If a truck fails, it could irritate the customer, which could result in lost business. Not only does Penske guarantee performance by investing heavily in its preventive maintenance program, but it also provides

replacement vehicles if a breakdown occurs.

Spec the Right Equipment

Equipment is the lifeblood of a private fleet, and Penske Truck Leasing's sales executives draw on their experience to help customers spec the right equipment to best fit their needs. Identifying the right equipment from the beginning creates a win-win situation for Penske, as well as for the customer.

Running a leased vehicle can also reduce a fleet manager's concerns over the unknowns associated with new engine technology.

Penske not only researches equipment prior to its release, but in some cases has also been involved in the production process.

For private fleets considering a new technology, such as automatic transmissions, leasing can provide an opportunity for drivers to try it before the fleet manager commits to it.

Improve Agility

Leasing can increase a company's flexibility as it can scale up or down based on demand. Many private fleets experience cyclical and seasonal business, so being nimble is important. Because leasing allows companies to flex as needed, customers can pursue new opportunities without being bound by equipment.

Obtain Broad Maintenance Coverage

A strong maintenance program, which is included in a full-service lease, ensures uptime. Routine preventive maintenance can improve safety, prevent breakdowns and minimize costly repairs down the road. Properly maintained vehicles avoid violations at roadside inspections, which helps private fleets improve

their scores within the Federal Motor Carrier Safety Administration's Compliance, Safety, Accountability program.

If a breakdown occurs on the road, Penske Truck Leasing either repairs it on site or provides a replacement vehicle, which improves uptime. Penske also provides substitute vehicles when warranty work or other

repairs need to be done.

Improve Safety

Safety is a top priority for many companies, and maintenance is critical for ensuring a safe, reliable fleet. The quality of maintenance Penske Truck Leasing provides is one of the primary reasons some companies opt for full-service leases.

Reduce Liability

Not maintaining equipment properly increases the amount of risk a company is exposed to, but using a full-service maintenance program shows equipment has been cared for properly, which can reduce liability if a problem occurs. What's more, Penske keeps detailed records on vehicle maintenance history.

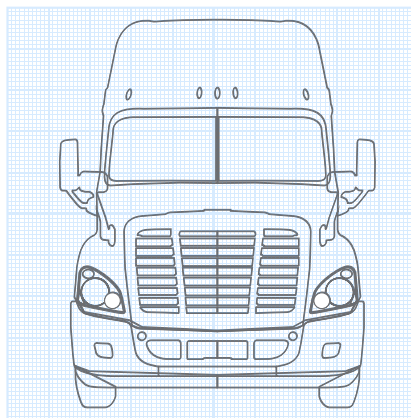

Having a third party manage maintenance also reduces the liability an on-site maintenance facility carries with it, such as labor and environmental requirements.

Retain Drivers

New, well-maintained equipment can help private fleets retain and attract quality drivers. Maintenance is important not only for safety, but also for driver acceptance. Because of hours-of-service regulations, drivers have 14 hours to get their work done once they clock in, and they don't want to be delayed because of equipment issues.

Streamline Back-Office Operations

As part of its services, Penske Truck Leasing provides detailed recordkeeping, which streamlines operations and ensures private fleets have the necessary information at the time of an audit. Full-service leases also minimize the time and effort the company invests

in licensing because Penske takes care of it. Plus, when it is time to part with a vehicle, utilizing a full-service lease allows a private fleet to turn it back in rather than having to spend time trying to sell it.

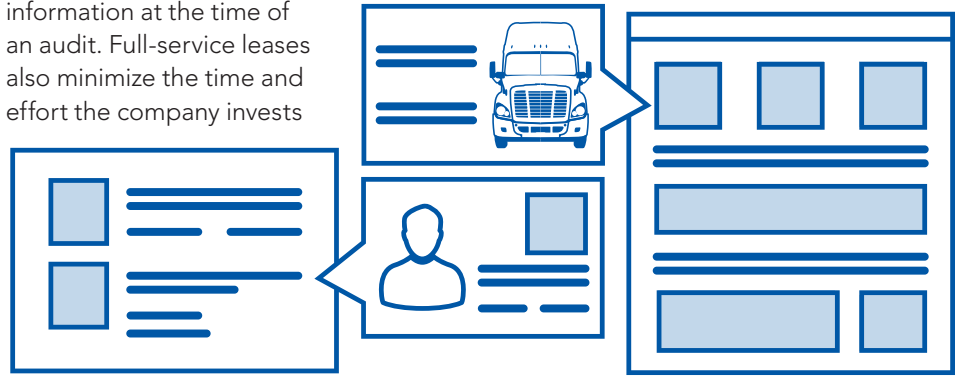

Penske's recordkeeping ensures private fleets have the necessary information at the time of an audit.

Contact Us

Contact your local Penske representative for more information.



Rental
Leasing
Logistics